



## VERIFICATION OF THE CODE TO CALCULATE DUCT FLOW AFFECTED BY EXTERNAL MAGNETIC FIELD

I.A. Smolyanov<sup>1</sup>, E.I. Shmakov<sup>1</sup>, E. Baake<sup>2</sup> and M. Guglielmi<sup>2</sup>

<sup>1</sup>*Ural Federal University, Yekaterinburg, Russian Federation*

<sup>2</sup>*Leibniz University, Hannover, Germany*

In this paper, the authors present the results of software verification for solving magnetic hydrodynamic problem in duct exposed to constant magnetic fields. The proposed approach uses the following open source software: the OpenFOAM for solving problems of continuum mechanics using the finite volume method, the Elmer for solving magnetic field distribution based on the finite element method, and the EOF-library for data exchange between these two programs. The verification results were demonstrated by fluid flow in a square duct exposed to constant uniform spanwise magnetic field. The research was carried out with a laminar fluid flow, which makes it similar to the Hartmann's problem. The existing experience of calculating such problems, their verification and application were discussed. The paper provides a brief mathematical description of the proposed solution and basic procedures for implementation of the code proposed by the authors. At the first verification stage, the comparison of fluid velocity distribution results at Hartmann's numbers equal to 1, 10, 20 and 50 was demonstrated. These results were obtained by means of proposed software, an analytical solution, and a test problem provided by the OpenFOAM developers for two-dimensional case. At the second stage of software verification, sufficient convergence of the results was shown for fluid velocity distribution in the three-dimensional case of the Hartmann's problem compared with the OpenFOAM test problem data and the results obtained by Comsol Multiphysics and ANSYS. As a result, distributions of the fluid flow velocity between Hartmann's walls were obtained for various study cases: the two-dimensional problem, the three-dimensional problem with electrically insulated walls, and the three-dimensional problem with walls with infinite electrical conductivity. The last stage of the study corresponds to evaluation of software performance in comparison with the built-in OpenFOAM solver and commercial software Comsol Multiphysics and ANSYS. It was found that the proposed approach takes more time to calculate these problems than the built-in OpenFOAM solver, but less than Comsol. However, the problem formulation in the EOF-library allows solving problems with complex geometry, which is not available in the built-in OpenFOAM solver. In conclusion, analysis of computation performance with parallelization was carried out. It showed significant reduction of computation time with the help of the EOF-library in comparison with the commercial software Comsol and ANSYS.

**Key words:** magnetic hydrodynamics, software verification, OpenFOAM, Elmer, EOF-library

### 1. Introduction

Physical processes of magnetic hydrodynamics present in a number of industrial fields, for instance, in atomic power industry, metallurgical industry, measurement technologies etc. These processes are described by the partial differential equations, which can be solved only under significant assumptions. The use of numerical models [1–4] is the current trend in the magnetic hydrodynamics field. The main objective of the paper is firstly to present the results of verification and estimation of efficiency of the solver developed by the authors, which was designed for the problems of the duct flow affected by external magnetic field, to the scientific and engineering community and secondly to help the researches in choosing the adequate computational tools.

The problem of the fluid flow affected by external magnetic field is studied for understanding the processes in thermonuclear reactors [5], measurement of the Lorentz force [6] and the duct flow velocity [7], metal crystallization [8] and in many other applications. The magnetic field can behave like a solid obstacle [9] or conversely it can result in the fluid laminarization [10]. These phenomena are often considered as modifications of the Hartmann problem, as, for instance, in the papers [11, 12], where the magnetic field is assumed to be constant in time. The conclusions made in these papers are not acceptable for a number of engineering applications, for instance for the cases of varying and running magnetic fields, described in the papers [8] and [13] respectively. One of the problems is associated with designing the induction pump operating at the flow rate of 3 m<sup>3</sup>/s and pressure above 8 bar [14]. Under such conditions, strong turbulent flows, reverse flows as well as strong mechanical effects of the pump walls arise in the working channel, which makes the pump operation impossible. At the same time, the linear stability theory does not allow predicting the transition from laminar to turbulent regime with sufficient accuracy, while the experiment performance is complicated by the metal aggressiveness, opacity and high temperature. Therefore, there arises the necessity

in development of the numerical model, which is capable to predict the present systems' behavior with sufficient accuracy.

The present problems were solved with the use of commercial software packages such as ANSYS [15] and Comsol Multiphysics [16]. The fluid flow behavior in the complex shaped devices with thin walls with different electrical conductivity was studied for Hartmann numbers above 1000 with the use of ANSYS CFX 18.2, which is described in the papers [15, 17]. The Comsol Multiphysics software package was successfully applied for calculation of thermonuclear fusion in [16] and for calculation of induction pumps in [18, 19]. Some of the authors of the papers mentioned above had also developed their own codes in terms of magnetic hydrodynamics problems' solving [10, 20, 21]. The great contribution of the computational magnetic hydrodynamics development was made by the paper [22]. The authors of the mentioned paper had developed their own code for calculation of the fluid flow affected by constant magnetic field. The same authors had analyzed the correctness of using different turbulence models for different types of the magnetic hydrodynamics' problems in the paper [10]. The paper [13], where the fluid flows in non-idealized magnetic systems were studied on the basis of the HERACLES code [23] is of special interest for magnetic hydrodynamics problems' solving. In the paper [24], the authors propose a number of approaches to consideration of the magnetic field finiteness and vortex nature on the basis of the boundary conditions, which allows for the computational resources' reduction. Direct modeling was carried out by the authors of the papers [20, 21, 25], in which they considered the influence of magnetic effects on the fluid flow behavior.

The ability to implement a variety of problems is the advantage of the commercial numerical software packages, but at the same time it becomes a disadvantage in case of solving the problems which require special settings, however these problems can be solved by means of the open source programs, as in [26]. Generally, the open source programs for numerical modeling are designed for solving the specific problem and are tested on it, which makes it difficult to use this tool for other cases and requires additional validation.

Verification of the program code for calculation of the duct flows affected by magnetic field is considered in this paper. The considered code permits to combine the advantages of the finite element method in electromagnetic problems and the finite volume method in the fluid flows problems by means of the open source programs. Simplification of the initial problem statement to such an extent at which the analytical solution can be found is one of the well-known ways of the models' verification, as it was described in the paper [27]. It allows scaling the verification results for a wide range of problems and taking the analytical expressions, obtained in the papers [28, 29], as a reference. Therefore, at the first stage the numerical and analytical solutions for the two-dimensional case are compared in this paper. The effectiveness of using the built-in OpenFOAM solvers and the solver proposed by the authors in the two-dimensional and three-dimensional cases is compared as well as the performance of these solvers and the Comsol and ANSYS commercial packages is evaluated.

## 2. Mathematical model description

The phenomena of magnetic hydrodynamics in an incompressible fluid can be described by the equations of momentum and mass conservation:

$$\frac{\partial \mathbf{U}}{\partial t} + (\nabla \cdot \mathbf{U})\mathbf{U} - \nu \nabla^2 \mathbf{U} = -\nabla \frac{p}{\rho} + \frac{\mathbf{J} \times \mathbf{B}}{\rho}, \quad (1)$$

$$\nabla \cdot \mathbf{U} = 0,$$

where  $t$  is the current time of the process,  $\mathbf{U}$  is the flow velocity vector,  $\nabla$  is the nabla operator,  $\nu$  is the kinematic viscosity,  $p$  is pressure;  $\rho$  is density,  $\mathbf{J}$  and  $\mathbf{B}$  are the current density and magnetic induction vectors, respectively. The current density in the equation (1) can be defined from the Ohm's law in notation of calculus:

$$\mathbf{J} = \sigma \cdot (-\nabla \varphi + \mathbf{U} \times \mathbf{B}). \quad (2)$$

If the displacement currents are neglected in (2) and the current lines continuity is considered  $\nabla \cdot \mathbf{J} = 0$ , the following equation will be obtained:

$$\nabla^2 \varphi = \nabla \cdot (\mathbf{U} \times \mathbf{B}), \quad (3)$$

and the magnetic induction vector will be calculated according to the electromagnetic induction law as follows:

$$\frac{\partial \mathbf{B}}{\partial t} = \frac{1}{\mu_0 \sigma} \nabla^2 \mathbf{B} + \nabla \times (\mathbf{U} \times \mathbf{B}). \quad (4)$$

In equations (2)–(4) the following notations are accepted:  $\varphi$  is the electrostatic scalar potential;  $\sigma$  is the electrical conductivity;  $\mu_0$  is the magnetic conductivity.

The equation (4) can be rewritten as follows:

$$\Delta \mathbf{A} - \mu \sigma \nabla \varphi + \mu \sigma (\mathbf{U} \times \nabla \times \mathbf{A}) = -\mu \mathbf{J}, \quad (5)$$

where the following expression for the magnetic vector potential  $\mathbf{A}$  is used:

$$\mathbf{B} = \nabla \times \mathbf{A}.$$

The presented equations should be supplemented by the boundary conditions, which consider the properties of the duct walls ( $\Gamma$  surfaces):

– for isolated walls

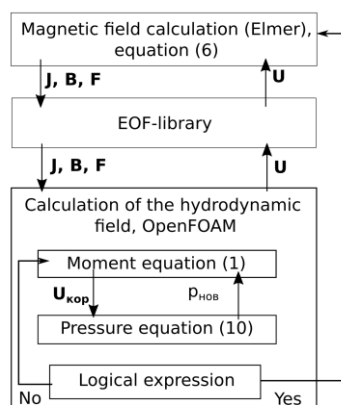
$$B(\Gamma) = B \quad \text{or} \quad \mathbf{J} \cdot \mathbf{n} = 0;$$

– for superconductive walls

$$\frac{\partial \mathbf{B}}{\partial \mathbf{n}} = 0 \quad \text{or} \quad \varphi(\Gamma) = 0.$$

The equations (1) and (4) can be solved by means of the «mhdFoam» built-in solver of the OpenFOAM open source software package [30]. The use of the finite volume method for the magnetic field calculation is the disadvantage of this approach. In real problems the magnetic systems often have complex configuration, which should be taken into account. In this case the numerical implementation of such problems by means of the finite element method is more stable as compared to the finite volume method. Moreover, there arise problems with the solution convergence due to the non-smoothness of the magnetic induction functional (4) in the areas of high currents or due to magnetic permeability changes.

The modernized OpenFOAM solver applicability for calculation of the hydrodynamic field  $\mathbf{U}_{\text{kop}}$  according



**Fig. 1.** Flow diagram of the proposed solver

to (1) by means of the finite volume method and calculation of the magnetic induction, the current density and the Lorentz force distribution in the Elmer open source program by means of the finite element method is considered in the present paper. The data exchange between these programs will be implemented by means of the MPI (Message Passing Interface) technology using the EOF-library [31]. Such procedure permits to run the programs in parallel and perform quick data exchange. These features are important for problems with complex geometry of computational domains and nonuniform distribution of the desired fields in space and time.

The flow diagram of the modernized solver is presented in Fig. 1. At the first step the EOF library relates the OpenFOAM mesh to the Elmer meshes. Then the magnetic field is calculated in the Elmer software package. The determined values of the forces, the magnetic induction and the current are transferred to the hydrodynamic

equations (1) by means of the EOF library. After the data transfer the velocity field is calculated in the OpenFOAM software package. At each time step solution is corrected by pressure

$$\nabla^2 p = f(\mathbf{U}, \nabla p)$$

and the logical expression is checked. If it is true the magnetic problem is recalculated according to the current velocities' values. One can establish any logical expression, for instance, at a certain value of the relative difference between the maximum speed values at the previous and the current time step it can be considered true. In the present study the magnetic problem recalculation is performed at each time step of the solver.

It should be mentioned that at the present stage of solver development the possibilities of using the averaged and the instantaneous values of the forces are implemented, namely: the magnetic problem can be solved not only at each time step, but also at each N-iteration of the solver at the specified user time interval or in accordance with the specified logical expression.

### 3. Results

The problem of the fluid flow in rectangular duct of the length  $L = 20$  m and the cross section of width  $2a$  and height  $2b$  (Fig. 2) is solved. At the duct inlet the velocity value is set. For calculation convergence improvement and calculation time reduction the velocity is set as a parabolic function. In such a way, according to Hartmann, the developed flow is achieved in less time. The magnetic field passes through two horizontal duct walls, is uniformly distributed in space perpendicular to the fluid flow and does not change with time.

Let us consider the square duct ( $a = b$ ). The non-uniform orthogonal mesh with a number of elements of  $n_x \times n_y \times n_z = 100 \times 60 \times 60$  is used in the numerical calculations. The mesh layers' size is  $2b/Ha$ , where  $Ha$  is the Hartmann number:

$$Ha = B \cdot b \sqrt{\frac{\sigma \rho}{\nu}} \tag{6}$$

The mesh layer thickness at the walls perpendicular to the field is reduced to  $2a/Ha^{0.5}$ ; the number of elements at the walls parallel to the magnetic field is set as 10. For calculations simplification the Hartmann numbers (6) as well as such physical properties as electrical conductivity  $\sigma$ , density  $\rho$ , kinematic viscosity  $\nu$ , and a half the height of the duct  $b$  are set equal to 1, and the magnetic induction  $\mathbf{B}$  varies depending on the required value of the Hartmann number. The following assumption also permits to reduce the derivative time constant of the equation (1) and perform a less number of time steps. At all duct walls the no-slip conditions are fulfilled and at the outlet the pressure value is set to zero and the reverse flows are assumed to be possible.

The results obtained in calculations can be divided in three groups: comparison of the two-dimensional models, comparison of the three-dimensional models, comparison of the calculation time in standard numerical modeling software packages. The data obtained by means the following programs is presented below:

- the proposed solver;
- the standard «mhdFoam» solver implemented in the OpenFOAM program;
- the analytical solution for the two-dimensional case according to the equation

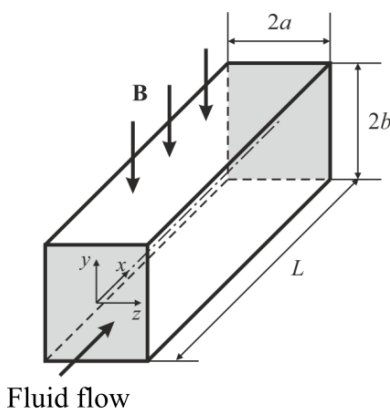
$$U_x = U_0 \frac{\cosh(Ha) - \cosh(Ha \cdot y/2b)}{\cosh(Ha) - \sinh(Ha/2b)} \tag{7}$$

- the commercial software packages Comsol and ANSYS.

The expression (7) includes the following variables:  $2b$  is the duct height;  $y$  is the coordinate along the magnetic field direction;  $U_x$  and  $U_0$  are the velocity in the flow distribution direction and its characteristic value respectively. For all the cases the following is accepted: the Reynolds number  $Re = U_0 b / \nu = 1$ ; the magnetic Reynolds number  $Re_m = \sigma \mu_0 u b \ll 1$ ; the magnetic Prandtl number  $P_m = Re_m / Re \ll 1$ .

#### 3.1. Comparison of the two-dimensional models

The results, obtained on the basis of the two-dimensional models with an assumption that the duct has the infinite width, are compared below.



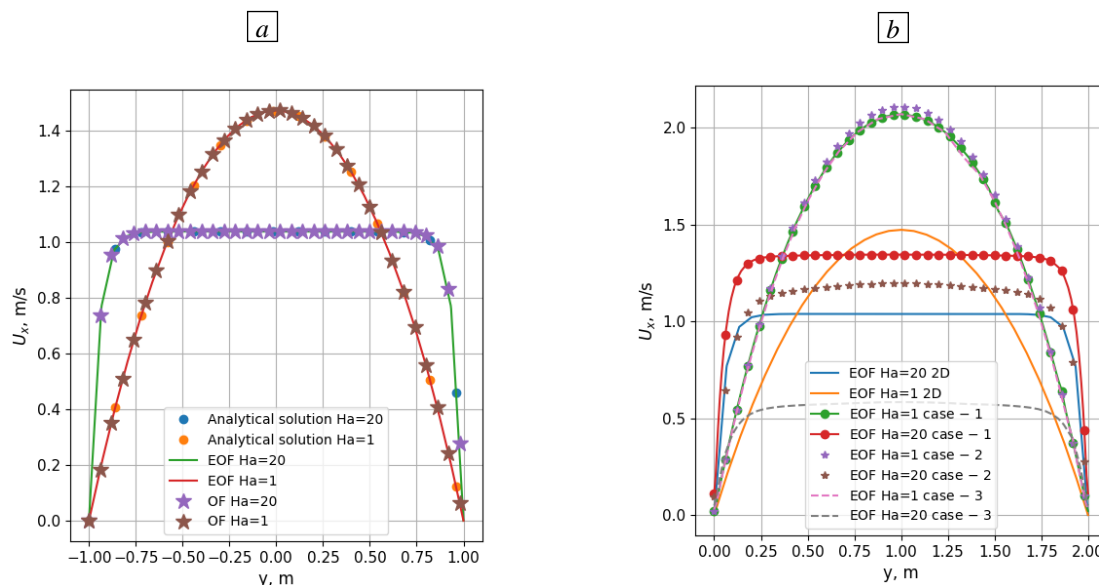
**Fig. 2.** Diagram for the problems solving

This approach allows for the model verification by means of the analytical expression (7), presented in the paper [28]. The velocity distributions between the walls perpendicular to the magnetic field for the Hartmann numbers equal to 1 and 20 are presented in Fig. 3a. These values were calculated with the use of the following programs: the built-in «mhdFoam» solver in the OpenFOAM program (are indicated by OF on the graph); the solver with the use of the EOF library, proposed by the authors (are indicated by EOF on the graph) and the analytical solution (7). The results obtained by numerical calculation are in good agreement with the analytical solution.

It should be mentioned that the magnetic field has a uniform distribution over the duct volume and a weakly expressed vortex nature. In case of the real problems the velocity profile will be different, and generally the analytical solutions are not found due to many physical phenomena, which should be considered in the mathematical model. The present conclusions are confirmed by the calculation results shown in Fig. 3b, where in addition to the two-dimensional problem the data based on the three-dimensional problem statement for different boundary conditions at the duct walls, mentioned below, is presented:

- 1) all the walls are isolated;
- 2) the walls perpendicular to the magnetic field direction possess infinite conductivity, while the walls parallel to the magnetic field are isolated;
- 3) all the walls possess infinite conductivity.

Therefore in order to achieve the proposed code verification goal and evaluate the code accuracy it is important to perform the calculations for the three-dimensional statement and different boundary conditions.

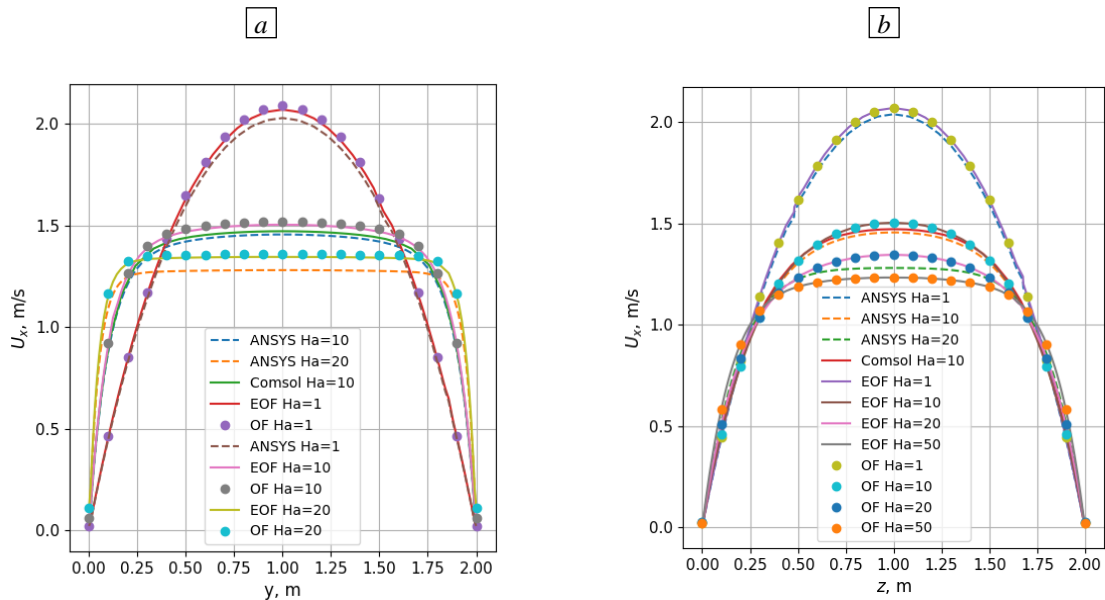


**Fig. 3.** Comparison of velocity distribution between the duct walls, perpendicular to the magnetic field direction for the Hartmann numbers equal to 1 and 20: calculation with the use of standard «mhdFoam» solver (OF curves) and the authors' solver (EOF curves) in case of two-dimensional (2D) problem statement (a); the EOF calculation in case of the two-dimensional and three-dimensional problem statement (for this case the boundary conditions 1, 2, 3 are considered) (b)

### 3.2. Comparison of the three-dimensional models

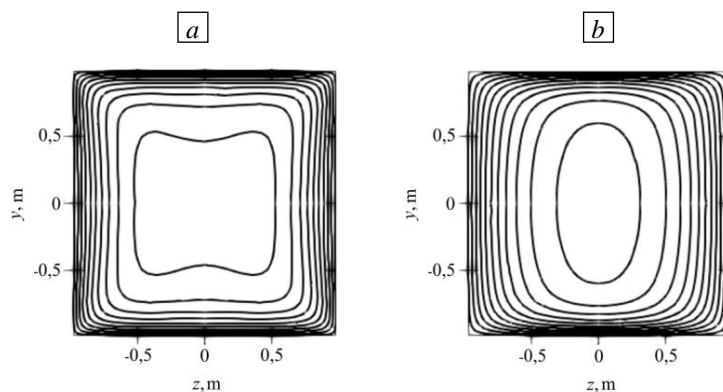
The next step is the verification of the authors' solver for the three-dimensional model, which permits to consider the fluid adhesion not only at the walls perpendicular to the magnetic field but also at the walls parallel to the magnetic field. Consideration of the no-slip boundary condition is important due to the fact that the sharp in the near-wall regions is the main reason for the duct flows' instability, because the shear stress increase in its turn is caused by the fluid adhesion. Moreover, in a three-dimensional model, it becomes possible to consider the vortex nature of the velocity field in all spatial directions, which is also important for the analysis of flows in systems affected by the constant magnetic field, and therefore, for answering the question of how the magnetic field affects the resulting forces. Comparison of calculation results obtained in different software packages, including the authors' code, will permit to evaluate the results accuracy. The velocity distributions between the superconducting walls are shown in Fig. 4. The difference between the curves obtained by standard solver (OF) and by means of the EOF library is less than 1 % for the Hartmann numbers equal to 1 and 20. The imprecision can be caused on the one hand by the insufficiently accurate calculation mesh in the

near-wall region with the highest velocity gradient, and on the other hand by interpolation of data, involved in the exchange between the OpenFOAM and Elmer programs. The results, obtained in ANSYS software package, differ from the other results more than others. It can be explained by specific features of the ANSYS Fluent module, designed for the magnetic hydrodynamics problems solving. In this module the boundary condition should be resolved by the finite elements, which leads to reduction of the fluid duct cross section by the wall mesh thickness size, specified in the program settings. In problems where the effect of wall thickness is important, this fact can help to simplify the mathematical model.

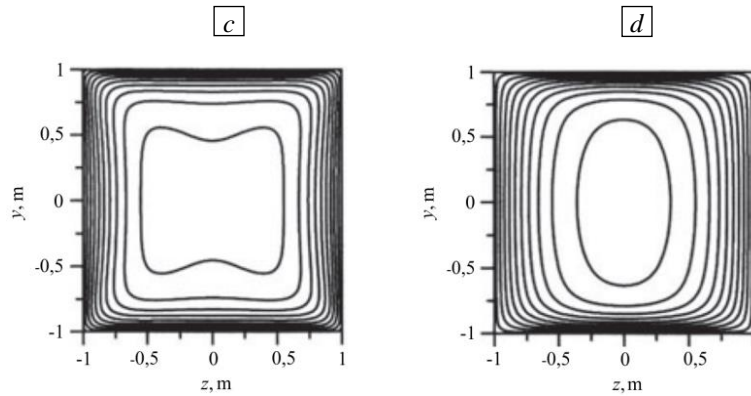


**Fig. 4.** Comparison of velocity distribution in the duct with isolated walls: the walls are perpendicular (a) and parallel (b) to the magnetic field

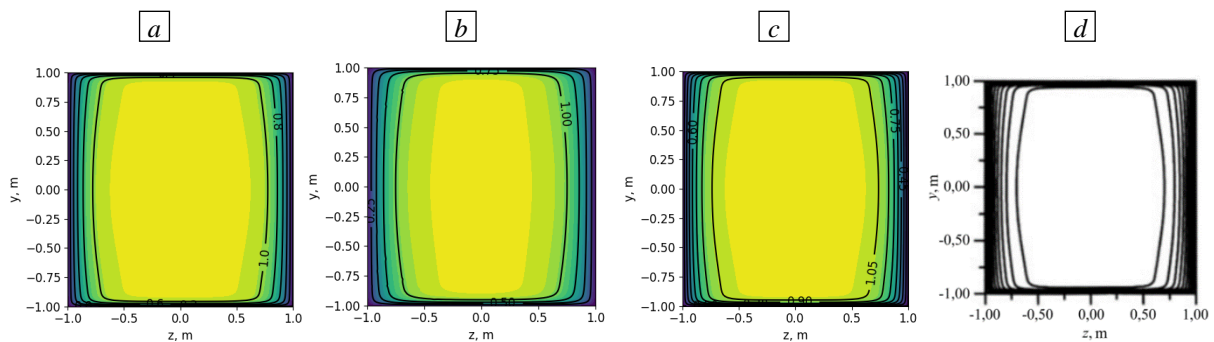
The near-walls layers shift, as it was shown earlier, introduces the flow instability. In a number of the magnetic hydrodynamics’ problems, especially in case of non-idealized constant magnetic flows, where the completion of the current path in space and time plays an important role, these paths can have complex structure, in particular at the areas with significant magnetic field gradient. In these cases the current density distribution in duct is an important parameter, because its value directly influences the forces distribution. Plotting the velocity lines of the similar level is one of the ways to evaluate the current density distribution. The velocity isolines in the duct cross section for the Hartmann numbers equal to 10 are shown in Fig. 5. The similar results were obtained in the paper [32], where the isolines were identical for both boundary conditions. The velocity isolines for Ha=50 are presented in Fig. 6. The present isolines were calculated by different ways: with the use of EOF library; by means of the OpenFOAM standard solver; by means of the ANSYS Fluent commercial software package; analytically [32]. It can be concluded that the proposed solver based on the EOF library provides good convergence in comparison with other data.



**Fig. 5.** The velocity isolines in the duct cross section: calculation be means of the EOF library (a, b), analytical solution [32] (c, d); the walls have infinite electrical conductivity (a, c), isolated walls (b, d)

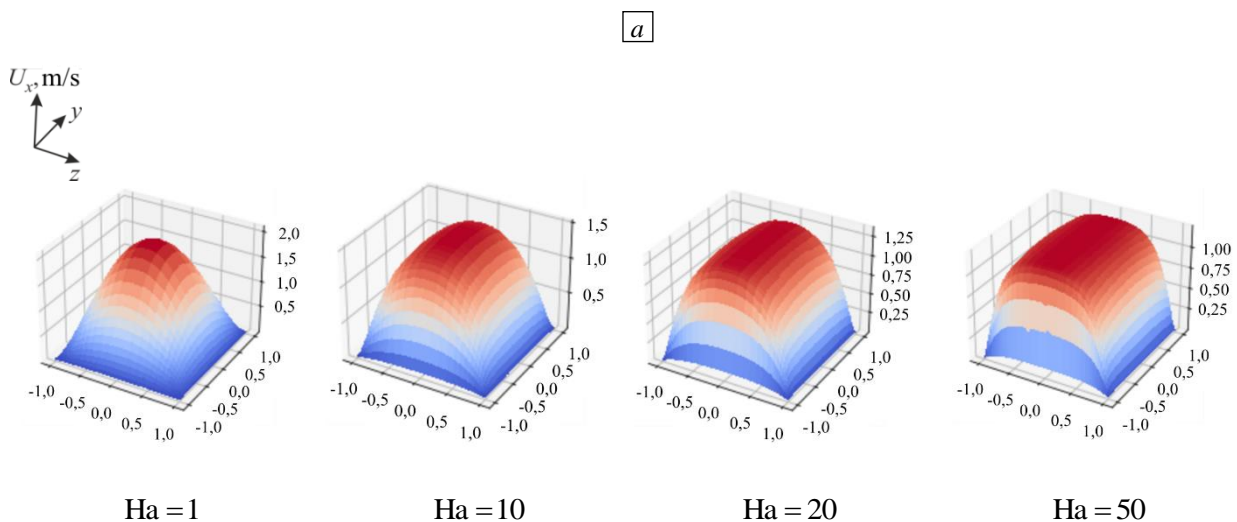


**Fig. 5.** Continuation

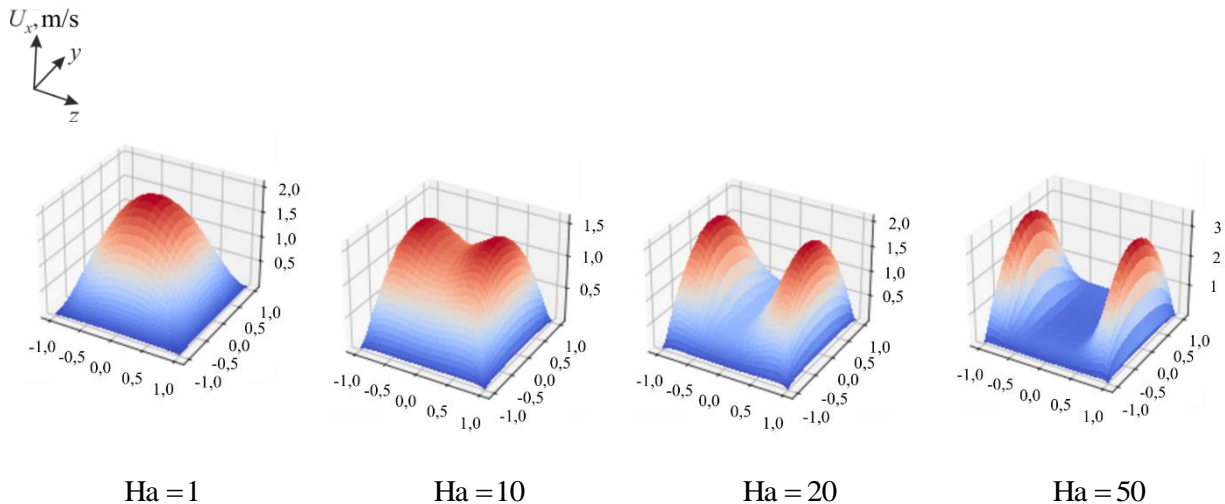
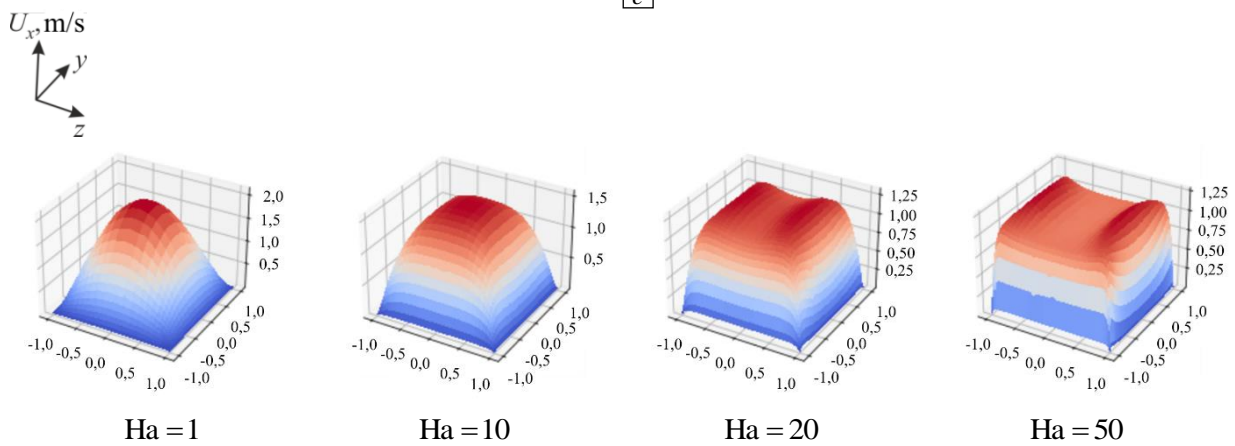


**Fig. 6.** The velocity isolines in the duct cross section for the Hartmann number equal to 50, obtained by different ways: by means of the authors’ solver with the EOF library (a); OpenFOAM (b); ANSYS (c); analytically [32] (d)

The qualitative comparison of the fluid flow under the constant magnetic field for the main three boundary conditions [32], described above, is the last stage of the proposed code verification. The velocity distribution plots in the duct cross section are shown in Fig. 7. These plots qualitatively replicate the results of the numerical experiments well-known in magnetic hydrodynamics, described in [27] or [32].



**Fig. 7.** Isosurfaces for the duct velocity in case of different boundary conditions: all the walls are made of isolation material (a); walls perpendicular to the magnetic field direction possess infinite conductivity and the walls parallel to the magnetic field are isolated (b); all the walls have infinite conductivity (c)

**b****c****Fig. 7. Continuation**

### 3.3. Comparison of calculation time

The calculation time is an important criterion of the chosen mathematical problem statement and the solving method efficiency. Let us compare the time for the Hartmann problem calculation by means of the EOF library, the OpenFOAM built-in solver and the Comsol Multiphysics commercial software package. All three mentioned variants differ by the applied methods. The standard OpenFOAM solver is implemented on pure finite volume method, the EOF library combines the finite element method and the finite volume method, while in the Comsol Multiphysics the pure finite element method is used. In all three cases the linear equations solution was found and selection of sampling circuits in space and time was performed in accordance with default settings of the enumerated software packages.

The duct with isolated walls was calculated. In this case the flow was analyzed for the Hartmann number equal to 10. The calculation data is summarized in the table. It can be seen from the table that:

- the best result was obtained by the OpenFOAM standard solver. But it should be mentioned that the calculation time increases significantly in case of consideration of the non-uniform fields, while in case of the problem parallelization the calculation time is reduced. But this solver is appropriate only for the constant field analysis and it does not comprise tools for modeling of non-idealized systems where the field source design features should be considered, for instance for studies of fluid flow in the running magnetic field;
- the Comsol Multiphysics performance is limited by the fact that the calculations parallelization tool is not presented in the explicit form and in therefore only the finite element method can be applied. At the same time the intuitive interface, which permits to create complex multiphysics' models, is the advantage of the present software package;



– the authors' solver is stable and has a good results' convergence both in solving classical physical problems and in analyzing the real devices. The main disadvantage is in the necessity to operate with two open source programs such as Elmer and OpenFOAM, which use different syntax, and knowledge of the C++ programming language can be required to change the conditions of magnetic and hydrodynamic problems combination.

Table. Time to solve the problem of fluid flow in a square duct affected by the constant uniform magnetic field perpendicular to the fluid flow

Software package	Architecture			
	2 cores	4 cores	8 cores	12 cores
OpenFOAM	4 min	2 min	1.5 min	1.5 min
EOF library	33 min	18 min	12.5 min	10.5 min
Comsol	250 min	–	48 min	–
ANSYS	40 min	–	30 min	–

#### 4. Conclusion

The author' code for solving problems of the fluid flow in the rectangular ducts affected by constant magnetic field was verified and its qualitative and quantitative evaluation was performed. The performed studies had shown that difference between the results obtained with the use of the authors' code and the analytical solution [32] is less than 1%. The quantitative comparison of the velocities distribution along the duct walls calculated by the following methods was performed: with the use of numerical software packages with the open license for magnetic field calculation (Elmer), continuum mechanics (OpenFOAM), the library of these software packages connection (EOF-library) as well as ANSYS and Comsol commercial software packages. The qualitative evaluation of velocity distribution in the duct cross section in case of different boundary conditions at the duct walls was performed on the example of the three-dimensional fluid flow statement. It has also shown the authors' results adequacy.

The evaluation of various numerical software packages has shown that the OpenFOAM standard solver had the highest calculation speed, but opposed to the EOF library it does not permit to perform complex calculations for electromagnetic problem. The ability to perform quasi-steady calculations of electromagnetic field on the basis of the EOF library is a one more advantage over the OpenFOAM standard solver, which does not work with the complex numbers. The absence of the built-in modules for current calculation in coils with a complex shape can be distinguished among the proposed code weaknesses. These options are included in the Comsol Multiphysics and ANSYS commercial software packages. The code efficiency in case of calculations parallelizing with the use of the EOF library was compared to the other software packages efficiency. It was found that an increase in the cores number with the same amount of random access memory leads to computation time reduction by more than 3 times. In this case the possibility of separate configuring of the magnetic and hydrodynamic problems parallelization is opened, which will help to improve of the authors' code performance in future and expand the range of problems being solved.

Summarizing the results described above, the following can be stated:

1. The performed verification of the authors' code has shown adequacy of solutions obtained by this code.
2. The highest solution stability for the same meshes was obtained for the authors' code in combination with the EOF library.
3. When using the EOF library as well as C++ and Fortran program language the unique boundary conditions can be stated.
4. The absolute values of flow velocities in duct are significantly affected by the electromagnetic boundary conditions.
5. The proposed code is not limited by solving the laminar flows affected by constant magnetic field, but it has a vast scope of application, a number of applications can be found in papers [20, 21, 31].

It should be also mentioned that the further papers will be devoted to investigation of the running magnetic field effect on velocity distribution in the induction pump.

The study was performed with the financial support of the RFBR within the framework of the scientific project No. 20-38-90237.

## References

1. *Kim H.R., Lee Y.B.* A design and characteristic experiment of the small annular linear induction electromagnetic pump // *Ann. Nucl. Energy.* 2011. Vol. 38. P. 1046-1052. <https://doi.org/10.1016/j.anucene.2011.01.008>
2. *Araseki H., Kirillov I.R., Preslitsky G.V., Ogorodnikov A.P.* Magnetohydrodynamic instability in annular linear induction pump: Part I. Experiment and numerical analysis // *Nucl. Eng. Des.* 2004. Vol. 227. P. 29-50. <https://doi.org/10.1016/j.nucengdes.2003.07.001>
3. *Abdullina K.I., Bogovalov S.V., Zaikov Yu.P.* 3D numerical modeling of liquid metal turbulent flow in an annular linear induction pump // *Ann. Nucl. Energy.* 2018. Vol. 111. P. 118-126. <https://doi.org/10.1016/j.anucene.2017.08.010>
4. *Dong X., Mi G., He L., Li P.* 3D simulation of plane induction electromagnetic pump for the supply of liquid Al-Si alloys during casting // *J. Mater. Process. Tech.* 2013. Vol. 213. P. 1426-1432. <https://doi.org/10.1016/j.jmatprotec.2013.03.006>
5. *Smolentsev S., Abdou M.* Dual-coolant lead-lithium (DCLL) blanket: Status and R and D in the area of mhdthermofluids and fluid materials interaction // *Magnetohydrodynamics.* 2015. Vol. 51. P. 509-517. <https://doi.org/10.22364/mhd.51.3.11>
6. *Thess A., Votyakov E.V., Kolesnikov Y.* Lorentz force velocimetry // *Phys. Rev. Lett.* 2006. Vol. 96. 164501. <https://doi.org/10.1103/PhysRevLett.96.164501>
7. *Ratajczak M., Wondrak T., Stefani F., Eckert S.* Numerical and experimental investigation of the contactless inductive flow tomography in the presence of strong static magnetic fields // *Magnetohydrodynamics.* 2015. Vol. 51. P. 461-471. <https://doi.org/10.22364/mhd.51.3.7>
8. *Vakhrushev A., Kharicha A., Liu Z., Wu M., Ludwig A., Nitzl G., Tang Y., Hackl G., Watzinger J.* Electric current distribution during electromagnetic braking in continuous casting // *Metall. Mater. Trans. B.* 2020. Vol. 51. P. 2811-2828. <https://doi.org/10.1007/s11663-020-01952-3>
9. *Tympel S., Boeck T., Schumacher J.* Laminar and transitional liquid metal duct flow near a magnetic point dipole // *J. Fluid Mech.* 2013. Vol. 735. P. 553-586. <https://doi.org/10.1017/jfm.2013.491>
10. *Zikanov O., Krasnov D., Boeck T., Thess A., Rossi M.* Laminar-turbulent transition in magnetohydrodynamic duct, pipe, and duct flows // *Appl. Mech. Rev.* 2014. Vol. 66. 030802. <https://doi.org/10.1115/1.4027198>
11. *Li Y., Zikanov O.* Laminar pipe flow at the entrance into transverse magnetic field // *Fusion Eng. Des.* 2013. Vol. 88. P. 195-201. <https://doi.org/10.1016/j.fusengdes.2013.01.087>
12. *Krasnov D., Thess A., Boeck T., Zhao Y., Zikanov O.* Patterned turbulence in liquid metal flow: Computational reconstruction of the Hartmann experiment // *Phys. Rev. Lett.* 2013. Vol. 110. 084501. <https://doi.org/10.1103/PhysRevLett.110.084501>
13. *Reddy K.S., Fauve S., Gissinger C.* Instabilities of MHD flows driven by traveling magnetic fields // *Phys. Rev. Fluids.* 2018. Vol. 3. 063703. <https://doi.org/10.1103/PhysRevFluids.3.063703>
14. *Geza V., Nacke B.* Numerical simulation of core-free design of a large electro-magnetic pump with double stator // *Magnetohydrodynamics.* 2016. Vol. 52, No. 3. P. 417-432.
15. *Siriano S., Tassone A., Caruso G., Del Nevo A.* MHD forced convection flow in dielectric and electro-conductive rectangular annuli // *Fusion Eng. Des.* 2020. Vol. 159. 111773. <https://doi.org/10.1016/j.fusengdes.2020.111773>
16. *Jiang Y., Smolentsev S., Jun J., Pint B., Kessel C.* Prediction of PbLi fluid flow and temperature field in a thermal convection loop for qualification of fusion materials // *Int. J. Heat Mass Tran.* 2021. Vol. 172. 121198. <https://doi.org/10.1016/j.ijheatmasstransfer.2021.121198>
17. *Siriano S., Tassone A., Caruso G.* Numerical simulation of thin-film MHD flow for nonuniform conductivity walls // *Fusion Sci. Tech.* 2021. Vol. 77. P. 144-158. <https://doi.org/10.1080/15361055.2020.1858671>
18. *Goldsteins L., Buligins L., Fautrelle Y.* Stalling instability of annular linear induction pumps // *Magnetohydrodynamics.* 2018. Vol. 54. P. 333-342. <https://doi.org/10.22364/mhd.54.4.1>
19. *Oshurko V.B., Mandel A.M., Solomakho K.G., Lednev V.N.* Induced crystallization principle for rapid 3D printing of steel melts // *Magnetohydrodynamics.* 2018. Vol. 54. P. 343-351. <https://doi.org/10.22364/mhd.54.4.2>
20. *Smolianov I., Shmakov E., Vencels J.* Numerical analysis of liquid flows exposed to travelling magnetic field. 1. Idealized numerical experiment // *Magnetohydrodynamics.* 2021. Vol. 57. P. 105-120. <https://doi.org/10.22364/mhd.57.1.9>

21. *Smolianov I., Shmakov E., Vencels J.* Numerical analysis of liquid flows exposed to travelling magnetic field. 2. MHD instabilities due to magnetic end effects // *Magnetohydrodynamics*. 2021. Vol. 57. P. 121-132. <https://doi.org/10.22364/mhd.57.1.10>
22. *Krasnov D., Zikanov O., Rossi M., Boeck T.* Optimal linear growth in magnetohydrodynamic duct flow // *J. Fluid Mech.* 2010. Vol. 653. P. 273-299. <https://doi.org/10.1017/S0022112010000273>
23. *González M., Audit E., Huynh P.* HERACLES: A three-dimensional radiation hydrodynamics code // *A&A*. 2007. Vol. 464. P. 429-435. <https://doi.org/10.1051/0004-6361:20065486>
24. *Bandaru V., Boeck T., Krasnov D., Schumacher J.* A hybrid finite difference-boundary element procedure for the simulation of turbulent MHD duct flow at finite magnetic Reynolds number // *J. Comput. Phys.* 2016. Vol. 304. P. 320-339. <https://doi.org/10.1016/j.jcp.2015.10.007>
25. *Blishchik A., van der Lans M., Kenjereš S.* An extensive numerical benchmark of the various magnetohydrodynamic flows // *Int. J. Heat Fluid Flow*. 2021. Vol. 90. 108800. <https://doi.org/10.1016/j.ijheatfluidflow.2021.108800>
26. *He Q., Chen H., Feng J.* Acceleration of the OpenFOAM-based MHD solver using graphics processing units // *Fusion Eng. Des.* 2015. Vol. 101. P. 88-93. <https://doi.org/10.1016/j.fusengdes.2015.09.017>
27. *Patel A., Pulugundla G., Smolentsev S., Abdou M., Bhattacharyay R.* Validation of numerical solvers for liquid metal flow in a complex geometry in the presence of a strong magnetic field // *Theor. Comput. Fluid Dyn.* 2018. Vol. 32. P. 165-178. <https://doi.org/10.1007/s00162-017-0446-9>
28. *Hartmann J.* Theory of the laminar flow of electrically conductive liquid in a homogeneous magnetic field // *K. Dan. Vidensk. Selsk. Mat. Fys. Medd.* 1937. Vol. 15(6). P. 1-28.
29. *Hunt J.C.R.* Magnetohydrodynamic flow in rectangular ducts // *J. Fluid Mech.* 1965. Vol. 21. P. 577-590. <https://doi.org/10.1017/S0022112065000344>
30. *Tassone A.* Magnetic induction and electric potential solvers for incompressible MHD flows. [https://www.researchgate.net/publication/313678022\\_Magnetic\\_induction\\_and\\_electric\\_potential\\_solvers\\_for\\_incompressible\\_MHD\\_flows](https://www.researchgate.net/publication/313678022_Magnetic_induction_and_electric_potential_solvers_for_incompressible_MHD_flows)
31. *Vencels J., Råback P., Geža V.* EOF-Library: Open-source Elmer FEM and OpenFOAM coupler for electromagnetics and fluid dynamics // *SoftwareX*. 2019. Vol. 9. P. 68-72. <https://doi.org/10.1016/j.softx.2019.01.007>
32. *Müller U., Bühler L.* Analytical solutions for MHD duct flow // *Magnetofluidynamics in Ducts and Containers*. Springer, 2001. P. 37-55. [https://doi.org/10.1007/978-3-662-04405-6\\_4](https://doi.org/10.1007/978-3-662-04405-6_4)

*The authors declare no conflict of interests.*

*The paper was received on 15.04.2021.*

*The paper was accepted for publication on 16.07.2021.*